



K2R GI1111CR | CVR



K2 GI1111C | CV



K2
GI1111C | CV

K2R
GI1111CR | CV

**SPECIFICHE
TECNICHE**

**TECHNICAL
SPECIFICATIONS**

**TECHNISCHE
DATEN**

**CARACTERISTIQUES
TECHNIQUES**

MULINO A MARTELLI
IMPACT CRUSHER
PRALLBRECHER
CONCASSEURS À PERCUSSION

TRAMOGGIA DI CARICO
FEED HOPPER
AUFGABEBUNKER
TRÉMIE ALIMENTATION

**ALIMENTATORE VIBRANTE
A BARROTTI VERSIONE "C"**
GRIZZLY FEEDER "C" VERSION
STANGENVIBRATIONSAUFGEBER
VERSION "C"
SCALPEUR VIBRANT VERSION "C"

**VAGLIO VIBRANTE A 2 PIANI
VERSIONE "CV"**
DOUBLE DECK VIBRATING
SCREEN "CV" VERSION
ZWEI DECKEN VIBRATIONSSIEB
VERSION "CV"
CRIBLE VIBRANT A DEUX ÉTAGES
VIBRANT VERSION "CV"

PRODUZIONE MASSIMA
MAX PRODUCTION
MAX LEISTUNG
PRODUCTION

PESO (SENZA OPTIONALS)
WEIGHT
GEWICHT
POIDS



K2 = 2000 x 3970 mm. - 5 m³
K2R = 2400 x 4570 mm - 6 m³

K2 = 970 x 3600 mm
K2R = 970 x 4000 mm

1020 x 2000 mm

360 Ton/h *

K2 = 37.000 Kg "C" - 37.500 Kg "CV"
K2R = 47.000 Kg

DIMENSIONI DI TRASPORTO
TRANSPORT DIMENSIONS
TRANSPORTABMESSUNGEN
DIMENSIONS DE TRANSPORT

**NASTRO TRASPORTATORE
PRINCIPALE**
MAIN BELT CONVEYOR
HAUPTFÖRDERBAND
TRANSPORTEUR PRINCIPAL

CINGOLI
TRACKS
RAUPENFAHRWERK
CHENILLES

**IMPIANTO ABBATTIMENTO
POLVERI**
DUST SUPPRESSION SYSTEM
STAUBABSAUGUNG
ABATTAGE DE POUSSIÈRE

POMPA TRAVASO GASOLIO
DIESEL TANK FILLING PUMP
DIESEL ÖLBEHALTERFÜLLPUMPE
POMPE DE REMPLISSAGE
RÉSERVOIR DE GASOIL

SEPARATORE MAGNETICO
MAGNETIC BAND SEPARATOR
MAGNETABSCHIEDER
SÉPARATEUR

K2 = 13820 x 3400 x 2550 mm
K2R = 17060 x 3600 x 3000 mm

1000 x 11250 mm

450 x 3800 mm

K2R SISTEMA DI RICIRCOLO

Vaglio vibrante ad un piano
1500 x 3500 mm.
Nastro trasportatore estrattore
sopra vaglio
Nastro trasportatore sotto vaglio
Nastro trasportatore brandeggiante
di ricircolo

**K2R RE-CIRCULATING SCREENING
SYSTEM**

Single deck vibrating screen
1500 x 3500 mm.
Side transfert conveyor
Collection conveyor
Re-circulating conveyor

K2R KREISLAUFSYSTEM

Ein Deck Siebmaschine
1500 x 3500 mm.
Ausstragförderband oben Siebmaschine
Förderband unter Siebmaschine
Schwenkbar förderband für Kreislauf
Rückführung

K2R SYSTÈME DE RECIRCULATION

Crible vibrant à un étage
1500 x 3500 mm.
Convoyeur à bande dessus crible vibrant
Convoyeur à bande sous crible vibrant
Convoyeur à bande pivotant
de recirculation

OPTIONAL

RADIOCOMANDO LIV.1 - LIV.2

RADIO REMOTE CONTROL
FERNSTEUERUNG
COMMANDE À DISTANCE

NASTRO LATERALE

SIDE BELT CONVEYOR
SEITENAISTRAGSFÖRDERER
BANDE TRANSPORTEUSE LATÉRALE
600 x 4500 mm

**POMPA PER IMPIANTO
ABBATTIMENTO POLVERI**

WATER PUMP FOR DUST
SUPPRESSION SYSTEM
SELBSTANLASSENDE PUMPE
FÜR STAUBABSAUGUNG
POMPE POUR INSTALLATION
D' ABATTAGE DE POUSSIÈRE

* La produzione massima dipende dal tipo di materiale trattato e dal settaggio del mulino

* The production depends of the material treatment and the C.S.S..

K2

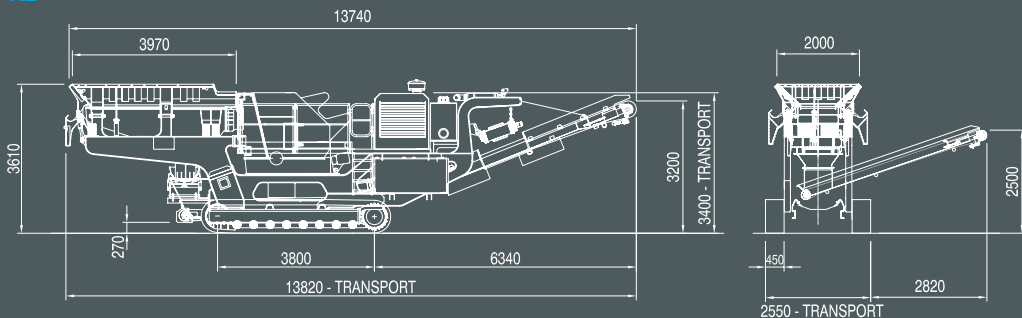

K2R

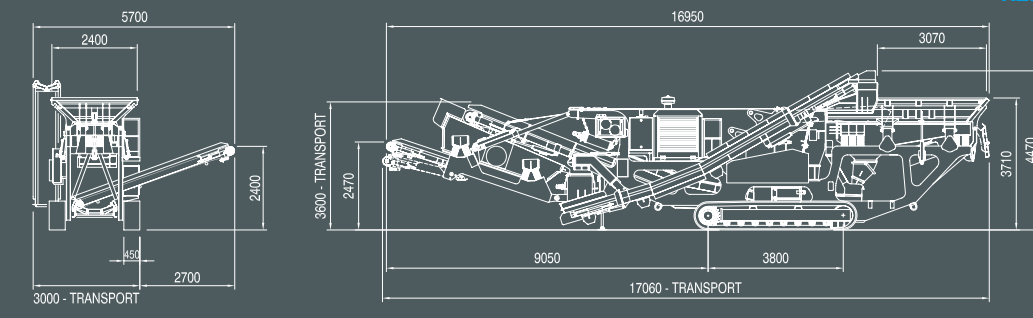

Via Giorgione, 17 - S.S. Feltrina
T +39 0423 670201
F +39 0423 676575

www.gasparin-omg.com
info@gasparin-omg.com

LOCAL UNIT
Via Palladio, 29
T +39 0423 670001
F +39 0423 670602
31040 Musano di Trevignano
(Trevise) Italy



YOUR PARTNER IN CRUSHING & SCREENING